

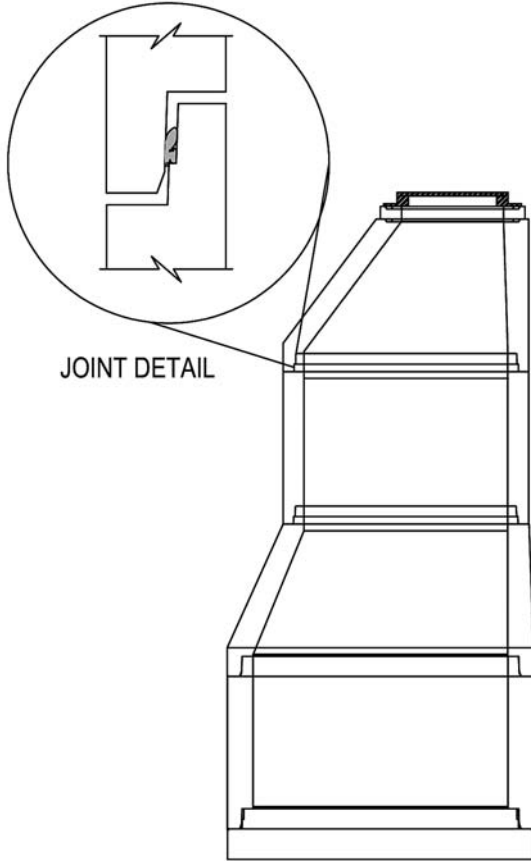

# Hanson



- Pre-Lubricated, gasketed manholes are ideal for:
  - Vacuum tested projects
  - High ground water situations
  - All precast manhole applications
- Money saving installation
- Tight consistent seal
- All product vacuum tested in plant
- Conforms to ASTM C-478

SERVING CENTRAL & NORTHERN CALIFORNIA

**12405 E. Brandt Rd.  
Lockeford, CA 95237**

**Tel: 209-797-1500**

**Fax: 209-797-1515**

[www.hansonpipeca.com](http://www.hansonpipeca.com)